



R-CONTROL SIPs

STRUCTURAL INSULATED PANELS



Note: Information deemed reliable at time of printing.
Please visit www.r-control.com for latest information. February 2008

**CONTROL,
NOT COMPROMISE.**

www.r-control.com



Architect/Engineering Review

The Load Design Charts for R-Control SIPs have been developed from national testing standards, testing at independent laboratories, and qualified structural engineers. They have been determined to be consistent with sound building practice. These charts cover most common construction requirements. Each building project should be reviewed by an architect/engineer to determine the suitability of R-Control SIPs.

The International Code Council Evaluation Service (ICC-ES) has reviewed the independent testing, structural engineering, and third party QC program conducted by PFS Corp. ICC-ES has issued evaluation report (code report) ESR-2233 covering R-Control SIPs. R-Control SIPs are recognized as being in compliance with the 2006 International Building Code and 2006 International Residential Code.



Construction Manual and Video Available

R-Control SIPs are structural components for use in load bearing wall, roof, ceiling, or floor assemblies. Contact us for a Construction Manual, technical specifications and a building techniques video. You can also download many of these documents from our website at www.r-control.com.

Example:

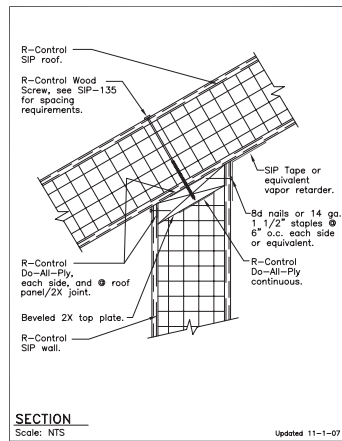

R-Control® SIP
TITLE: Beveled Wall Panel NO. SIP-122

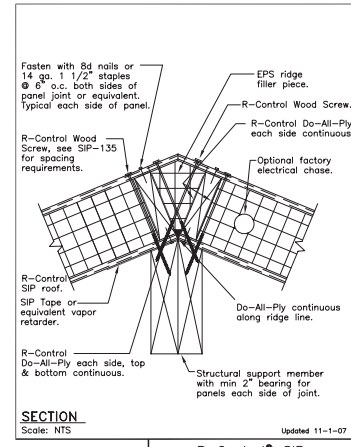

R-Control® SIP
TITLE: Roof Ridge - Square Cut NO. SIP-121a

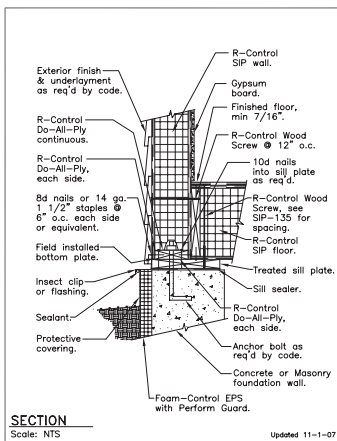

R-Control® SIP
TITLE: Foundation Framing - Panel NO. SIP-105b

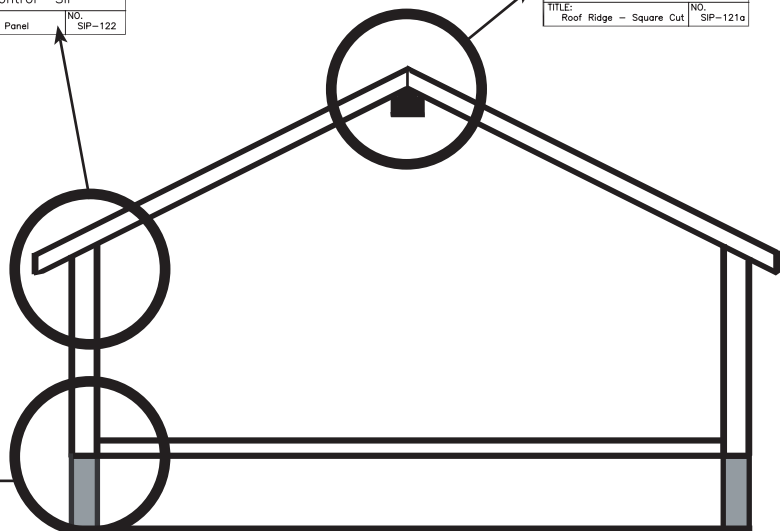

Table of Contents:

Pages

- 4-5..... Wall Design
- 6..... Header Design
- 7-10 Roof/Floor/Ceiling Design
- 11..... Diaphragm Design

Notes:

R-Control SIPs for Walls

- 2X top plate joints must be staggered a minimum of 1' from panel joints.
- For non-loadbearing walls, refer to Load Design Charts #4, #3, #3a, and #3b for transverse capacity.
- Double vertical boundary lumber of #2 Douglass Fir or better is required to achieve shear capacity.

R-Control SIPs for Roofs, Floors, or Ceilings

- Load Design Chart #1 provides transverse capacity using a surface or block spline detail for spans from 4' to 12'.
- Refer to Load Design Charts #3, #3a, and #3b for higher loads and/or longer spans than provided for in Load Design Chart #1.
- Minimum edge bearing for roof, floor, or ceiling panels is 1 1/2".
- For application of R-Control SIPs as flooring, a minimum 7/16" OSB or equivalent overlay is recommended to provide additional impact and point loading resistance.
- For sloped SIPs, the loading conditions and SIP capacities should be reviewed based upon the inclined panel length. Refer to R-Control SIP Technical Bulletin sip no. 2042.
- Load Design Chart #3, for spans greater than 22' and for all 1 1/4" core panels, the dimensional lumber is required to be #2 Douglas Fir or better.

R-Control SIPs used as Headers

- Load Design Chart #5 provides header capacity for R-Control SIPs. For higher capacities, code accepted framing is recommended.

R-Control SIPs used as a Diaphragm

- Diaphragms can be design with R-Control SIPs with capacities up to 850 plf. Refer to Load Design Chart #7.

R-Control SIP Deflections

- R-Control SIPs should be designed to comply with the deflection limits of the applicable building code. R-Control SIP Load Design Charts are for total load (dead load + live load). For long term deflection under sustained load (creep), additional deflection must be evaluated.

R-Control SIP 2X Lumber

- All R-Control SIP 2X Lumber shall be SPF#2, engineered equivalent, or greater; unless otherwise specified.

PANEL WEIGHT

	R-CONTROL® SIPs				
	SIP THICKNESS				
	4 1/2"	6 1/2"	8 1/4"	10 1/4"	12 1/4"
WEIGHT (p.s.f.)	3.3	3.5	3.6	3.8	4.0



Wall - Unity Equation

This equation is used to determine design suitability. The equation takes into account the ultimate load for a panel subjected to both axial and transverse (bending) conditions:

$$\frac{\text{design axial load}}{\text{allowable axial load}} + \frac{\text{design transverse load}}{\text{allowable transverse load}} \leq 1$$

(SEE LOAD DESIGN CHART 2B) (SEE LOAD DESIGN CHART 4)

Wall - Axial Loading LOAD DESIGN CHART #2B (SEE DETAIL SIP-101)

R-CONTROL® SIPs			
	PANEL HEIGHT	SIP THICKNESS	
		4 1/2"	6 1/2"
AXIAL LOAD [1] [PLF]	8' - 0"	2750	4000
	10' - 0"	2500	3500
	12' - 0"	2000	3000
	14' - 0"		2750
	16' - 0"		2500

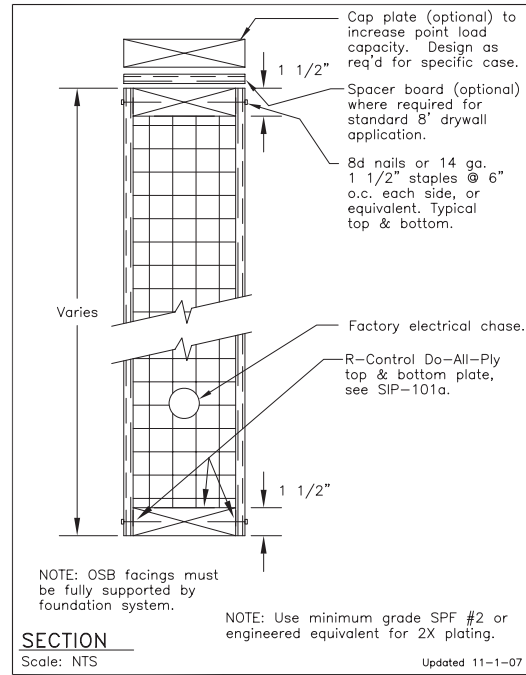

[1] LIMITED TO ULTIMATE FAILURE LOAD DIVIDED BY A FACTOR OF SAFETY OF THREE.

[2] PLEASE REVIEW NOTES ON PAGE 3.

R-Control® SIP	
TITLE: Plate Connections	NO. SIP-101

Wall - Shear Loading LOAD DESIGN CHART #6 (SEE DETAIL SIP-101)

R-CONTROL® SIPs			
	PANEL HEIGHT	SIP THICKNESS	
		4 1/2"	6 1/2"
RACKING SHEAR	N/A	335 PLF	335 PLF

[1] PLEASE REVIEW NOTES ON PAGE 3.

Wall - Transverse Loading
LOAD DESIGN CHART #4
(SEE SPLINE DETAILS SIP-102 or SIP-102g)

R-CONTROL® SIPS							
PANEL HEIGHT		SIP THICKNESS					
		4 1/2"			6 1/2"		
DEFLECTION		L/360	L/240	L/180	L/360	L/240	L/180
TRANSVERSE LOAD (PSF)	8' - 0"	28	40 ¹	40 ¹	42	61 ¹	61 ¹
	10' - 0"	20	30	32 ¹	32	48	49 ¹
	12' - 0"	15	22	27 ¹	26	38	41 ¹
	14' - 0"				21	31	35 ¹
	16' - 0"				17	26	31 ¹

- [1] LIMITED TO ULTIMATE FAILURE LOAD DIVIDED BY A FACTOR OF SAFETY OF THREE.
- [2] PLEASE REVIEW NOTES ON PAGE 3.

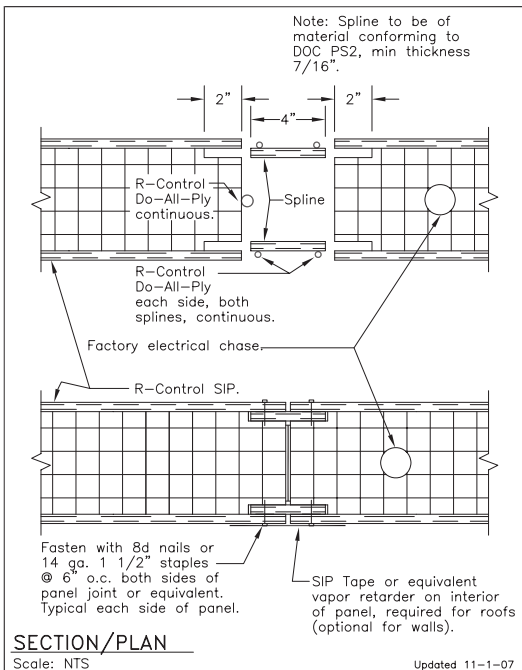

R-Control® SIP	
TITLE: Spline Connection Surface Spline	NO. SIP-102

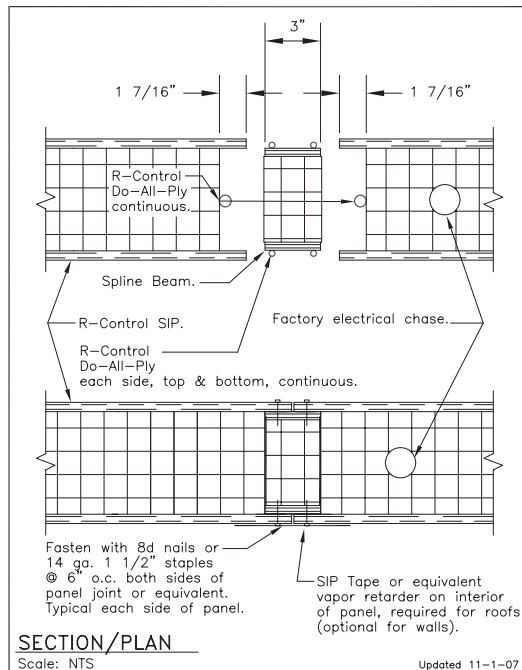

R-Control® Panel	
TITLE: Block Spline Connection	NO. SIP-102g



Wall - Header Loading
LOAD DESIGN CHART #5
(SEE DETAILS SIP-112 through SIP-114)

R-CONTROL® SIPs										
HEADER SPAN	HEADER DEPTH									
	12"			18"			24"			
DEFLECTION	L/480	L/360	L/240	L/480	L/360	L/240	L/480	L/360	L/240	
LOAD (PLF)	4'-0"	524	703	708 ¹	762	773 ¹	773 ¹	837 ¹	837 ¹	837 ¹
	6'-0"	319	374 ¹	374 ¹	466 ¹	466 ¹	466 ¹	557 ¹	557 ¹	557 ¹
	8'-0"	218	248 ¹	248 ¹	351 ¹	351 ¹	351 ¹	455 ¹	455 ¹	455 ¹

- [1] LIMITED TO ULTIMATE FAILURE LOAD DIVIDED BY A FACTOR OF SAFETY OF THREE.
- [2] PLEASE REVIEW NOTES ON PAGE 3.

Note: Details SIP-112a and SIP-112b are not illustrated here. Refer to R-Control SIP Construction Manual.

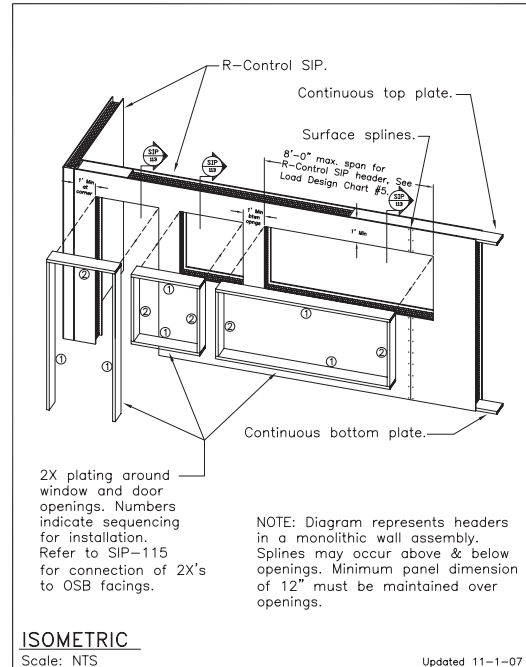
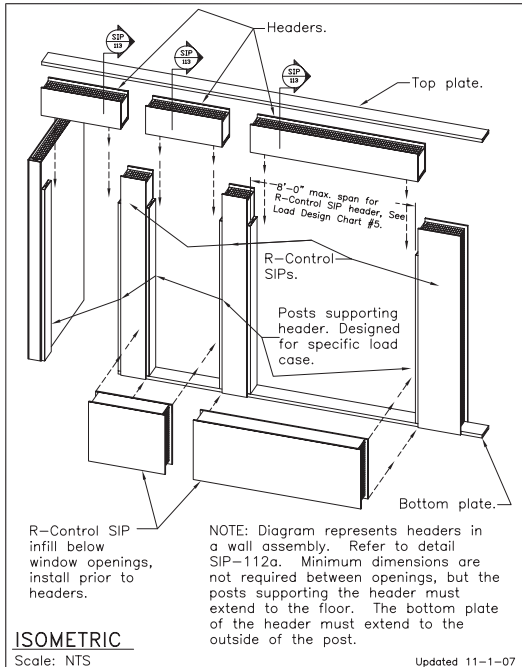
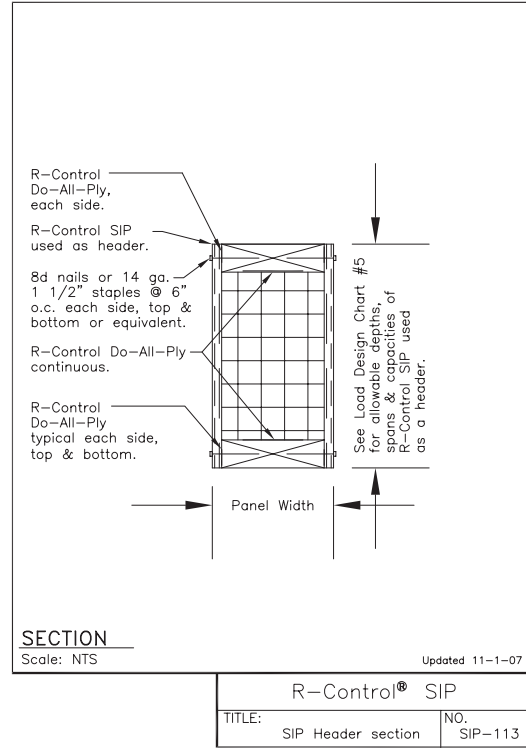

Roof/Floor - Transverse Loading

LOAD DESIGN CHART #1

(SEE SPLINE DETAILS SIP-102 or SIP-102g)

R-CONTROL® SIPS																
PANEL SPAN		SIP THICKNESS														
		4 1/2"			6 1/2"			8 1/4"			10 1/4"			12 1/4"		
DEFLECTION		L/360	L/240	L/180	L/360	L/240	L/180	L/360	L/240	L/180	L/360	L/240	L/180	L/360	L/240	L/180
TRANSVERSE LOAD (PSF)	4'- 0"	65	80 ¹	80 ¹	89	122 ¹	122 ¹	92	136 ¹	136 ¹	107	136 ¹	136 ¹	104	136 ¹	136 ¹
	6'- 0"	40	53 ¹	53 ¹	58	81 ¹	81 ¹	64	96 ¹	96 ¹	75	96 ¹	96 ¹	73	96 ¹	96 ¹
	8'- 0"	28	40 ¹	40 ¹	42	61 ¹	61 ¹	51	76 ¹	76 ¹	61	76 ¹	76 ¹	60	76 ¹	76 ¹
	10'- 0"	20	30	32 ¹	32	48	49 ¹	44	64 ¹	64 ¹	54	64 ¹	64 ¹	55	64 ¹	64 ¹
	12'- 0"							40	56 ¹	56 ¹	51	56 ¹	56 ¹	55	56 ¹	56 ¹

[1] LIMITED TO ULTIMATE FAILURE LOAD DIVIDED BY A FACTOR OF SAFETY OF THREE.

[2] PLEASE REVIEW NOTES ON PAGE 3.

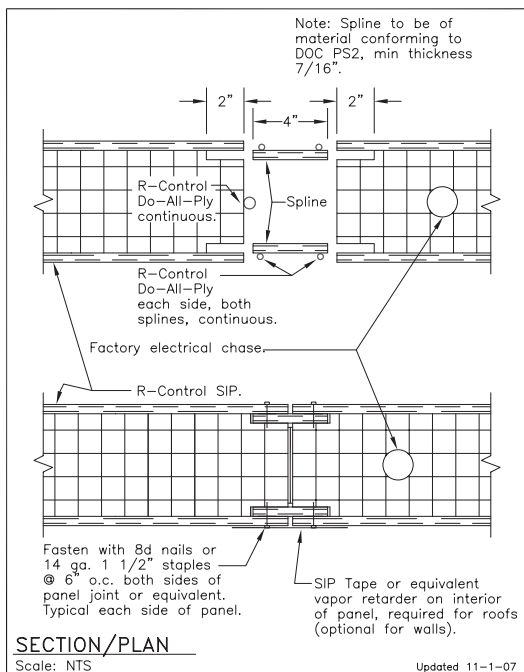

R-Control® SIP	
TITLE: Spline Connection	NO. SIP-102

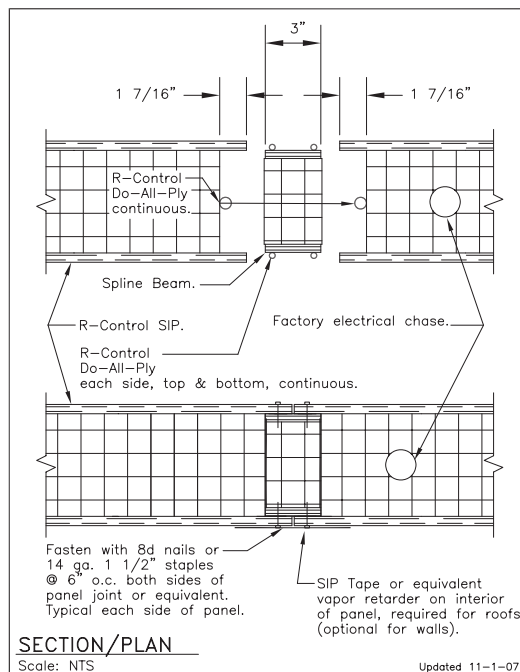

R-Control® Panel	
TITLE: Block Spline Connection	NO. SIP-102g



Roof/Floor - Transverse Loading

LOAD DESIGN CHART #3

(SEE DOUBLE 2X SPLINE DETAIL SIP-102d and SIP-108)

R-CONTROL® SIPs														
PANEL SPAN		SIP THICKNESS												
		6 1/2"			8 1/4"			10 1/4"			12 1/4"			
DEFLECTION		L/360	L/240	L/180	L/360	L/240	L/180	L/360	L/240	L/180	L/360	L/240	L/180	
TRANSVERSE LOAD (PSF)	10'-0"	53	79	105 ¹	89	109 ¹	109 ¹	150	174 ¹	174 ¹	177 ¹	177 ¹	177 ¹	
	12'-0"	40	59	79	65	91 ¹	91 ¹	111	145 ¹	145 ¹	148 ¹	148 ¹	148 ¹	
	14'-0"	30	45	60	48	72	78 ¹	84	124 ¹	124 ¹	115	127 ¹	127 ¹	
	16'-0"	24	35	47	37	55	68 ¹	65	98	109 ¹	89	111 ¹	111 ¹	
	18'-0"	19	28	37	28	42	57	51	77	97 ¹	70	99 ¹	99 ¹	
	20'-0"	15	22	30	22	33	44	41	61	82	56	84	89 ¹	
	22'-0"								33	49	66	45	68	81 ¹
	24'-0"								27	40	54	37	55	74

[1] LIMITED TO ULTIMATE FAILURE LOAD DIVIDED BY A FACTOR OF SAFETY OF THREE.

[2] DOUBLE 2X MUST BE CONTINUOUS AND SPACED 4' O.C.

[3] PLEASE REVIEW NOTES ON PAGE 3.

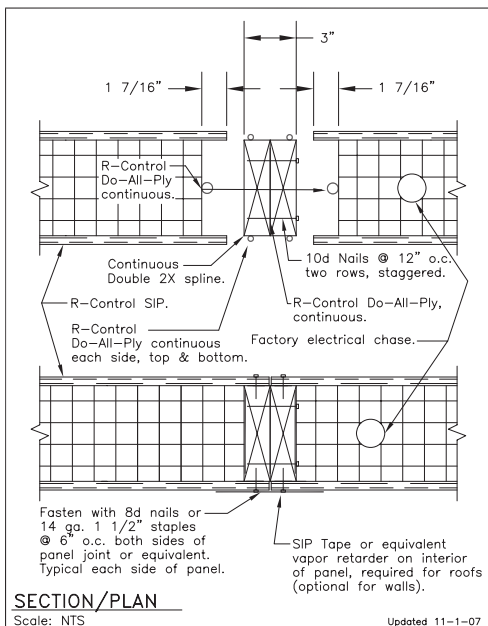

R-Control® SIP	
TITLE: Spline Connection Double 2X	NO. SIP-102d

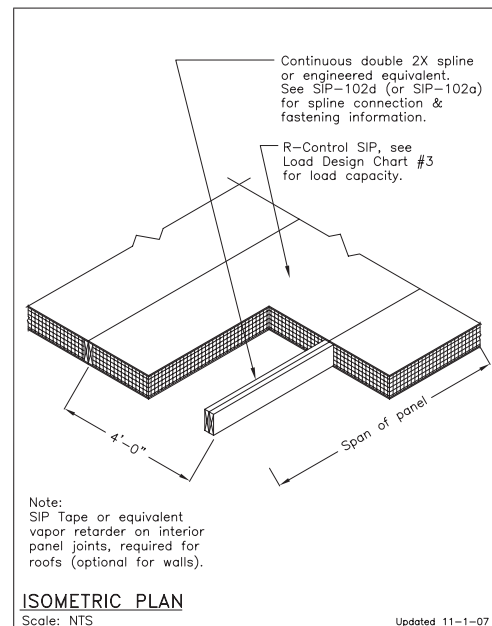

R-Control® SIP	
TITLE: Floor/Roof Panel 2X Connection	NO. SIP-108

Roof/Floor - Transverse Loading
LOAD DESIGN CHART #3A
 (SEE I-BEAM SPLINE DETAIL SIP-102b and SIP-108a)

R-CONTROL® SIPs										
PANEL SPAN		SIP THICKNESS								
		8 1/4"			10 1/4"			12 1/4"		
DEFLECTION		L/360	L/240	L/180	L/360	L/240	L/180	L/360	L/240	L/180
TRANSVERSE LOAD (PSF)	10'- 0"	81 ¹	81 ¹	81 ¹	118 ¹	118 ¹	118 ¹	131 ¹	131 ¹	131 ¹
	12'- 0"	63	68 ¹	68 ¹	98 ¹	98 ¹	98 ¹	109	109 ¹	109 ¹
	14'- 0"	49	58 ¹	58 ¹	73	84 ¹	84 ¹	87	93 ¹	93 ¹
	16'- 0"	38	51 ¹	51 ¹	55	74 ¹	74 ¹	69	82 ¹	82 ¹
	18'- 0"	30	45 ¹	45 ¹	42	63	65 ¹	55	72	72
	20'- 0"	24	37	40 ¹	33	49	59 ¹	45	65	65
	22'- 0"				26	39	49 ¹	37	55	57 ¹
	24'- 0"				21	31	41	30	46	48 ¹

- [1] LIMITED TO ULTIMATE FAILURE LOAD DIVIDED BY A FACTOR OF SAFETY OF THREE.
- [2] I-BEAM SPLINE MUST BE CONTINUOUS AND SPACED 4' O.C.
- [3] PLEASE REVIEW NOTES ON PAGE 3.

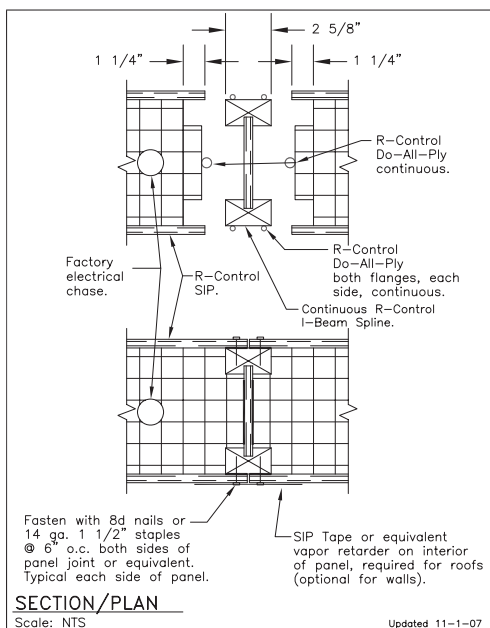

R-Control® SIP	
TITLE: Spline Connection I-Beam Spline Connection	NO. SIP-102b

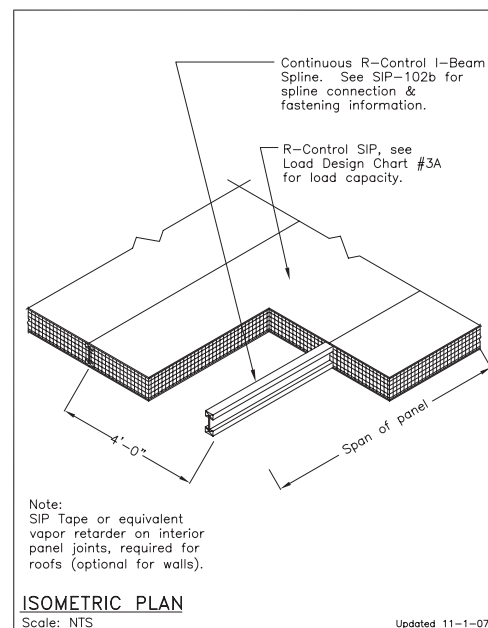

R-Control® SIP	
TITLE: Floor/Roof Panel I-Beam Connection	NO. SIP-108a



Roof/Floor - Transverse Loading

LOAD DESIGN CHART #3B

(SEE INSULATED I-BEAM SPLINE DETAIL SIP-102c and SIP-108b)

R-CONTROL® SIPs													
PANEL SPAN		SIP THICKNESS											
		6 1/2"			8 1/4"			10 1/4"			12 1/4"		
DEFLECTION		L/360	L/240	L/180	L/360	L/240	L/180	L/360	L/240	L/180	L/360	L/240	L/180
TRANSVERSE LOAD (PSF)	10'-0"	76	114	132 ¹	101	151	158 ¹	117	138 ¹	138 ¹	149 ¹	149 ¹	149 ¹
	12'-0"	53	79	96 ¹	72	109	132 ¹	88	115 ¹	115 ¹	124 ¹	124 ¹	124 ¹
	14'-0"	38	57	70 ¹	54	80	107 ¹	68	98 ¹	98 ¹	106 ¹	106 ¹	106 ¹
	16'-0"	28	42	54 ¹	40	61	81	53	80	86 ¹	76	93 ¹	93 ¹
	18'-0"	21	32	42	31	47	62	42	64	64 ¹	64	83	83
	20'-0"	16	24	32	24	36	49	34	51	52 ¹	50	74 ¹	74 ¹
	22'-0"							28	42	43 ¹	40	60	62
	24'-0"							23	34	36 ¹	33	49	52 ¹

[1] LIMITED TO ULTIMATE FAILURE LOAD DIVIDED BY A FACTOR OF SAFETY OF THREE.

[2] INSULATED I-BEAM SPLINE MUST BE CONTINUOUS AND SPACED 4' O.C.

[3] PLEASE REVIEW NOTES ON PAGE 3.

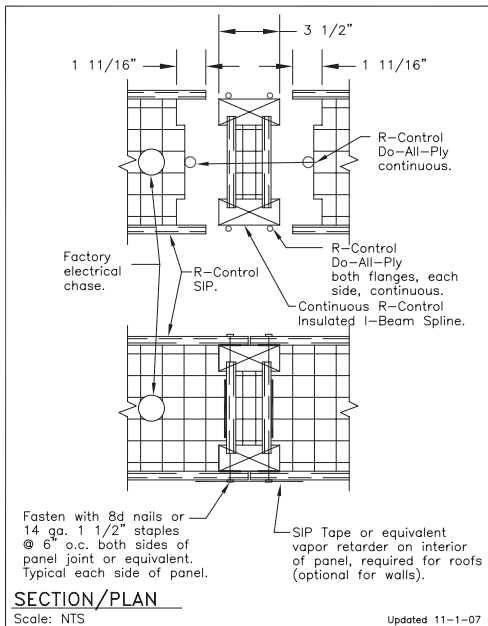

R-Control® SIP	
TITLE: Spline Connection Insulated I-Beam Spline	NO. SIP-102c

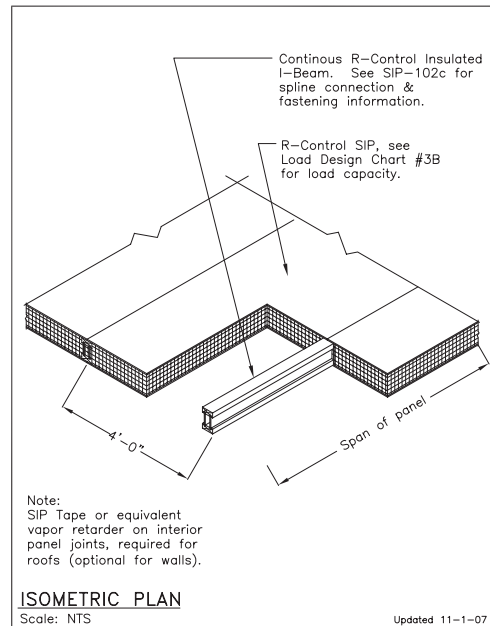

R-Control® SIP	
TITLE: Floor/Roof Panel Insulated I-Beam Connection	NO. SIP-108b

Roof/Floor - Diaphragm Loading

LOAD DESIGN CHART #7

(SEE CONNECTION DETAILS
SIP-139a, SIP-140 and SIP-141)

R-CONTROL® SIPS		
Spacing of R-Control SIP Fasteners at supported edges (minimum 1 5/8" penetration)		
3"	4"	6"
Spacing of spline fasteners ¹ (8d box or 6d common) at unsupported edges - top side of panel only - Two staggered rows of fasteners on each side of joint		
3"	3"	3"
850 PLF	750 PLF	500 PLF

[1] SPLINE IS 7/16" OSB x 4"

[2] PLEASE REVIEW NOTES ON PAGE 3.

Note: Detail SIP-139 is not illustrated here. Refer to R-Control SIP Construction Manual.

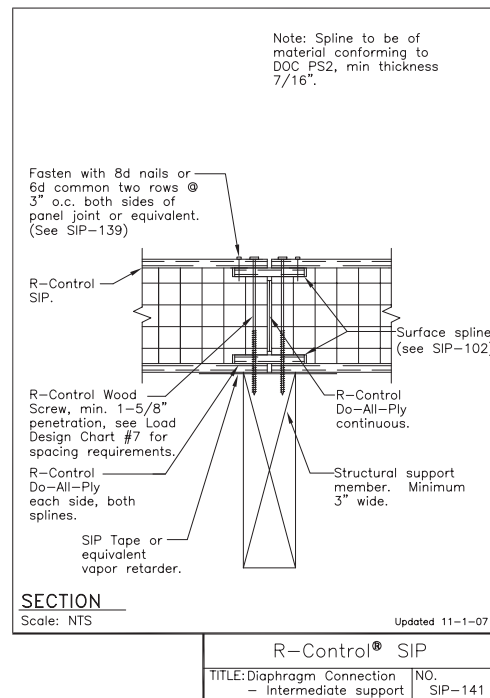
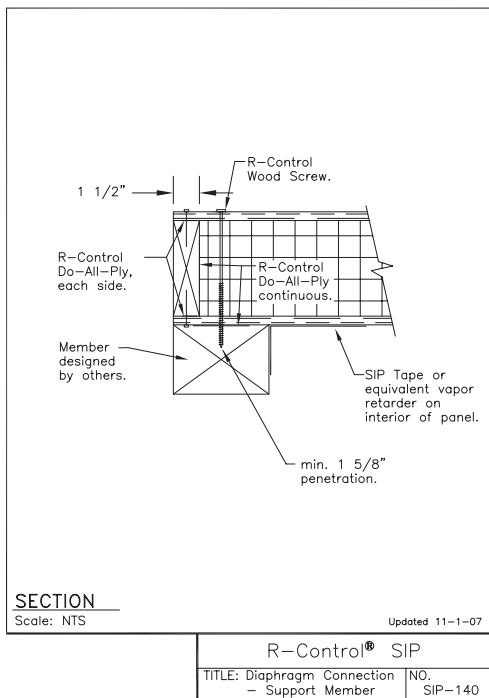
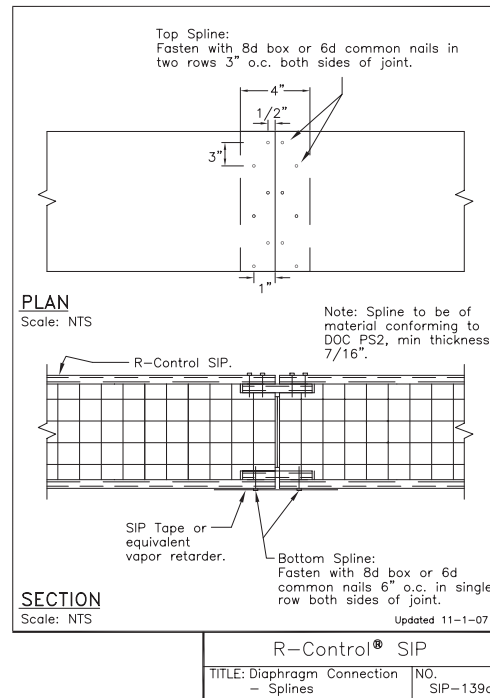

Ready to take control? Start here.

If you're wondering how R-Control SIPs can work on your next project, just contact your nearest R-Control supplier. They'll be happy to collaborate on design, walk you through R-Control SIP installation, provide test data, pricing, and answers to all your questions. Start by visiting our web site: www.r-control.com.



R-Control SIPs are made exclusively with Foam-Control EPS. R-Control SIPs and Foam-Control EPS are manufactured by AFM Corporation licensees.

Copyright ©2008 AFM Corporation. All rights reserved. Printed in USA. R-Control, Foam-Control, and Perform Guard are registered trademarks of AFM Corporation, Burnsville, MN.

RC02-02/08



R-Control SIPs
www.r-control.com

**CONTROL,
NOT COMPROMISE.**